

DREXEL®



DREXEL SLT-30/35AC

SWINGMAST® LIFT TRUCK

3,000 lb. (1,361kg) and
3,500 lb. (1,588kg) CAPACITY

STANDARD FEATURES

- Three-Wheel Configuration
- Rear-Wheel Drive and Steering
- High Visibility Mast (3 or 4-Stage)
- 90° Pivoting and Shifting Mast
- 48 Volt Electrical System
- Single Joystick Control Lever
- Adjustable Driver's Seat (15° Swivel Seat)
- Safety Seat Switch – Cuts Power
- Seat Belts
- Parking Brake, Electric, Mechanically Applied, Electrically Released
- Hydraulic Service Front Wheel Brakes
- AC Traction Control with Self-Diagnostics, Hour Meter and Battery Discharge Indicator with Lift Interrupt
- AC Hydraulic Pump Control
- Type "E" Construction
- Electronic Power Steering
- Automatic Return –to– Neutral
- SB 350 Blue Battery Connector
- Key Switch
- Covered Battery Compartment
- Battery Compartment Rollers
- Cushion Rubber Drive Tire (1)
- Polyurethane Load Tires (2)
- Horizontal Fork Indicator
- Overhead Guard
- Load Backrest
- Horn

OPTIONAL FEATURES

- Non-Standard Fork Lengths
- Dual Overhead Guard-Mounted LED Headlights
- Dual Rear Safety LED Light Bars
- Safety Flashing LED Light
- Backup Alarm - Beeping Tone ("Smart" dB Adjusting)
- Fire Extinguisher - OHG Post Mounted
- Cold Storage Conditioning to -22°F (-30°C)
- Lazer Fork Height Indicator
- Fork Positioner
- Keyless Key Pad On-Off
- Type EE Construction
- Single Auxiliary Hydraulics
- Landguide Wire Guidance



LANDOLL CORPORATION

MATERIAL HANDLING GROUP

www.landoll.com/mhp



SLT30-35AC-0116

DREXEL SLT-30AC / SLT-35AC

SwingMast® | Electric Forklift Truck

TECHNICAL DATA

MODEL			SLT30AC	SLT35AC
Capacity at 24" L/C		lbs/kg	3,000 / 1,361	3,500 / 1,588
Load Center		in/mm	24 / 600	24 / 600
Power Source			Battery, Electric 48V	Battery, Electric 48V
Weight with Battery		lbs/kg	13,225 / 5,999	13,550 / 6,146
Travel Speed	Loaded	mph/kph	6 / 9.7	6 / 9.7
	Unloaded	mph/kph	7 / 11.3	7 / 11.3
Lift Speed	Loaded	fpm/mpm	95 / 29	95 / 29
	Unloaded	fpm/mpm	110 / 33.5	110 / 33.5
Lower Speed	Loaded	fpm/mpm	80 / 24.4	80 / 24.4
	Unloaded	fpm/mpm	75 / 22.8	75 / 22.8
Mast Tilt	Fwd / Back	deg	3 / 4	3 / 4
Lost Load Center	A	with Triple Mast	in/mm	23 / 584
Wheelbase	B		in/mm	56 / 1,422
Overall Length to Fork Face	C	with Triple Mast	in/mm	89 / 2,260
Underclearance	D		in/mm	4.5 / 114
Cab Floor Height	E		in/mm	31 / 787
Seat Height	F		in/mm	50.75 / 1,289
Overhead Guard Height	G		in/mm	87 / 2,210
Chassis Width	H		in/mm	45.5 / 1,156
Mast Shift	I		in/mm	20 / 508
Side Reach	J		in/mm	3 / 76
Fork Carriage Width	K		in/mm	31 / 787
Turning Radius	L		in/mm	67 / 1,702
Standard Forks (ITA Class II)		in/mm	40 x 4 x 1.5	40 x 4 x 1.5
			1,016 x 101 x 38	1,016 x 101 x 38
Gradeability	Loaded	%	10	10
Lift Motor Rating		kWh	12	12
Steer Motor Rating		kWh	1.1	1.1
Traction Motor Rating		kWh	12	12
Wheel Sizes	Front (2 Each)	in	18 x 9 x 12.1	18 x 9 x 12.1
		mm	457 x 229 x 307	457 x 229 x 307
	Rear (1 Each)	in	18 x 7 x 12.1	18 x 7 x 12.1
		mm	457 x 178 x 307	457 x 178 x 307
Control Type	Traction		AC	AC
	Hydraulic		AC	AC

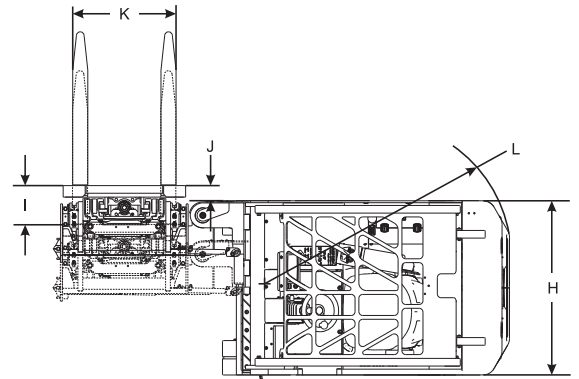
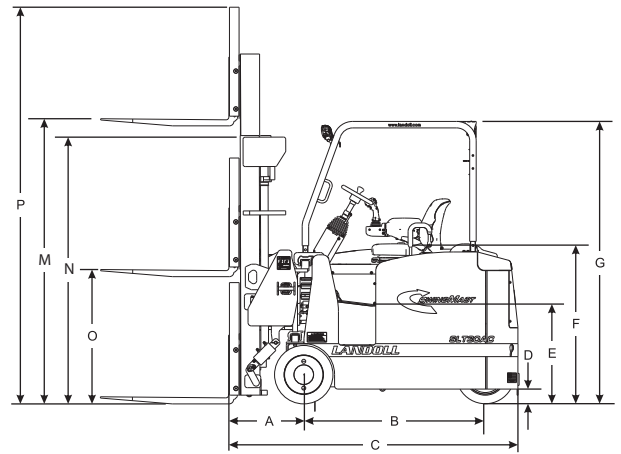

RECOMMENDED BATTERY

RECOMMENDED BATTERY
Battery Designation: 24-125-13, 48 Volt, 750 AHC (6 Hour Rate)
Battery Weight: Min. 2,750 lbs. (1,247kg) - Max. 3,300 lbs. (1,497kg)
Leads: Position D, 24" (61cm) Long, with SB 350 Amp Blue Connector
Nominal Size: 38.25" x 20.75" x 30.56" (971 x 527 x 776mm)
Battery Compartment Inside Dimensions: 38.5" x 21.5" x 31.5" (978 x 546 x 800mm)



MAST DIMENSIONS

LIFT HEIGHT (M)		LOWERED HEIGHT (N)		**FREE LIFT (O)		OVERALL HEIGHT (P)	
In	M	In	M	In	M	In	M
Mast Dimensions 3 Stage Full Free Lift							
188	4.78	83	2.11	47	1.19	224	5.69
198	5.03	87	2.21	51	1.30	234	5.94
205	5.21	90	2.29	54	1.37	241	6.12
216	5.49	95	2.41	59	1.50	252	6.40
223	5.66	98	2.49	62	1.57	259	6.58
242	6.15	107	2.72	71	1.80	278	7.06
258	6.55	115	2.92	79	2.01	294	7.47
272	6.91	121	3.07	85	2.16	308	7.82
Mast Dimensions 4 Stage Full Free Lift							
250	6.35	87	2.21	51	1.30	286	7.26
258	6.55	89	2.26	53	1.35	294	7.47
276	7.01	95	2.41	59	1.50	312	7.92
294*	7.47	101	2.57	65	1.65	330	8.38
312*	7.92	107	2.72	71	1.80	348	8.84
* Tilt Restricted to 1° Forward and 2° Backward							
** Free Lift Based on 36" (914mm) High Load Backrest							

The specifications contained in this spec sheet are subject to change at any time without notice. Actual dimensions and performance data given herein may vary due to manufacturing tolerances.

www.landoll.com/mhp

1900 North Street | Marysville, KS 66508 | (800) 428-5655



Intertek

